

weber flow-captor



Operating Pressure now
up to 100 bar (1.500 psi)



flow-captor Type 412-.52/.53M S141

The flow-captor type 412-.52/.53 M is a family of compact, precise metering flow switches with analog display in a rugged stainless steel housing. They operate based on the calorimetric principle.

The flow-captor allows you to set an exact flow set-point and will measure and display the flow rate via 9 LED's representing the flow range.

- Precise switching flow monitor for water or oil-based solutions up to 100 bar
- High accuracy even under low flow conditions
- Separate adjustment for "range" and "set-point"
- Analog display of actual flow rate and display of adjusted set-point value
- LED display for output status
- ISO 9002 certified manufacturing

Adjustments / Display

Measuring range adjustment	RANGE potentiometer
Measuring range display	9 LED display
Set-point adjustment	SET-POINT potentiometer
Set-point display	blinking LED
Switch output display	GREEN LED (on with flow)

Models

Type 4120.52/.53 M	for water based solutions
Type 4121.52/.53 M	for oil based solutions

Metering flow switch for water and oil-based medium with outstanding accuracy even at low flow conditions.

flow-captor

Type 412-.52/.53 M
metering flow switch

Typical Application

Examples:

The flow-captor 412-.52/.53 M can be applied where exact flow set-points are required, e.g. in systems where a signal is required at a slight deviation of the flow rate above or below the nominal value.

The flow-captor can optimize existing processes in a wide variety of industrial applications.

Technical Data

Type	4120.52/.53 M	4121.52/.53 M
Medium	water-based solutions	oil-based solutions

Sensor Data

Measuring Range	0 - 20 cm/s to 0 - 300 cm/s cont. adjust ¹⁾	0 - 30 cm/s to 0 - 300 cm/s cont. adjust ²⁾
Set-point range	approx. 15% - 90% of measuring range setting	
Medium temperature	- 20 °C to +80 °C (- 4 °F to +176 °F)	
Ambient temperature	- 20 °C to +70 °C (-4 °F to +158 °F)	
Pressure	up to max. 100 bar (1,500 psi)	
Response time	2 s to 10 s, acc. to range setting	2 s to 15 s, acc. to range setting
Accuracy	< 3 % ¹⁾	< 3 % ²⁾
Repeatability	< 1 %	
Hysteresis	approx. 10 %	

Mechanical Data

Protection class	IP 67
Housing material	stainless steel WN 1.4305 (V2A)
Sensor head	stainless steel WN1,4305 (V2A, 303 Ti) WN1.4571(V4A, 316 Ti), Titanium, Hastelloy C4® on request
Thread	G½ A (½" BSP), alt. ½" - 14 NPT
Electrical Connection	Binder male socket 4 pin + connection cable 4x0,5 mm², 2 m with female connector

Electrical Data (Electronic housing)

Operating voltage	115 V AC (90-170 V AC)	
Initial operation	approx. 10 s after connection of power	
Switching current	170 mA	
Electrical output	n.o. ⁴⁾ : .52	n.c. ³⁾ : .53
Switching function display	flow < set-point: LED off	flow > set-point: LED on

Notes: ¹⁾ data applies to water ²⁾ depends on oil solution type ³⁾ switch open with flow ⁴⁾ switch closed with flow

Dimensions

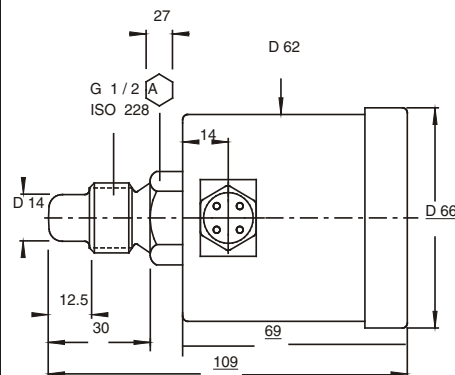

Dimensions in mm
D66x109/69

Connection Diagram

