

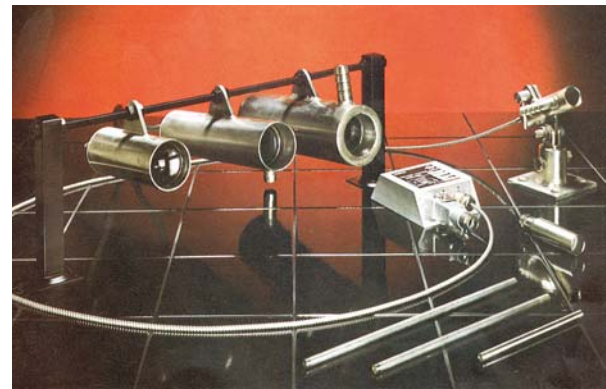

foto-captor: Hot Metal Detector System designed for harshest environments



The remarkable foto-captor

is the leading hot product sensor throughout the world's steel industry. Its highly advanced infrared radiation technology and design concept serve sophisticated industrial systems in metal manufacturing, heat treatment and glass making.

With more than 50 years of experience, our foto-captors are produced for tough, demanding industries and guaranteed by our commitment to supply high accuracy, long-life reliability and dependable performance with each one of our maintenance-free sensors, even in the harshest environments.

Well respected throughout the industry as problem solvers in infrared detection, we developed a wide range of foto-captor types with various response temperatures, remote lens systems, fiber optic cables, cooling jackets, air purges and other smart accessories to accommodate many different applications in hot product detection.

The foto-captors are compensated for high ambient temperatures and don't require adjustment. The highly selective viewing fields and temperature set-points prevent signaling outside these parameters.

Make sure, it's a captor

Operating Principle

The infrared radiation, received through the lens system, is transmitted to an IR detector. When the radiation exceeds a trigger point, the electrical switching output is activated.

The special foto-captor electronic circuitry compensates for ambient temperature changes and component aging.

Adjustment is therefore not necessary, thus providing higher operational safety and reliability. Three different set-point temperatures provide optimal temperature responses.

Typical Applications

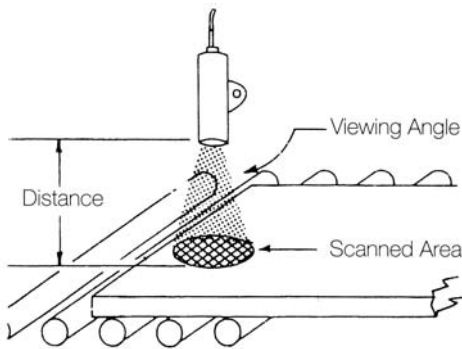

The sketch above indicates a typical application in a slab mill. The viewing angle determines the scanned area.

For example:

If a foto-captor type 1331.-- is installed at a viewing distance of 2m (6.5 ft.), the scanned area has a diameter of 28 cm (11 in.). foto-captor type 1331.-- has a set-point temperature of 450 °C (842 F). Therefore, hot steel at 450 °C (842 F) must cover the entire area before the foto-captor switches.

If hot product exceeds 450 °C (842 F), less of the scanned area needs to be filled to get a switching signal, (see temperature response diagram).

Application

The foto-captor hot metal detector is an infrared switch especially designed for fault-free operation in the harsh environments of heavy industry. For more than 50 years foto-captors have been successfully installed to monitor hot products in:

- **Rolling mills**
to control cut to length shearing, monitor hot rods, controlling roller tables, coil regulating, switching in crosscut hauler, monitor de-sealer, cooling beds, winder control, monitor edge washing, continuous casting or tracking of high speed wire.
- **Coke ovens**
to monitor quenching, cutting off press, monitoring exhaust gas flare and conveyors in ovens.
- **Forges and Foundries**
to monitor pouring and casting processes, position control.
- **Refuse Incinerators**
to monitor oven conveyor belt.
- **Blast Furnaces**
to monitor waste
- **Glassworks**
to monitor mold and stamping dies.
- **General Industry**
wherever infrared radiation requires a reliable signal.

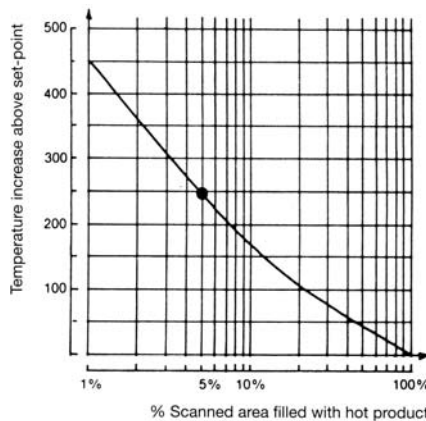

Design Features

foto-captors are rugged infrared switches completely epoxy resin encapsulated in stainless steel housings.

foto-captors are designed to be impervious to the effects of steam, water, dust, shock, vibration and oily conditions associated with heavy industrial environments.

They are temperature compensated for extreme ambient temperature conditions.

Available Options

- **Integrated test circuit**
to provide a pre-check prior to actual monitoring of hot product (as required for computer controlled production processes).
- **Remote fiber optic lens systems**
- **Cooling jackets**
for water or air cooling applications in areas with very high ambient temperatures.
- **Air Purge units**
If ambient air is influenced by dust or steam, housings are available with an air purge to enable the lens to be freed from obstructions with compressed air.
- **Swivel Stand**
for free movement on all 3 axles.

foto-captor Type Code

foto-captors are available with different temperature ranges, viewing angles, housings, cooling jackets and electrical outputs. They are supplied with and without fiber optics, integral or remote lens systems. Please see our "Type Code Chart" to identify the part number of your desired unit.

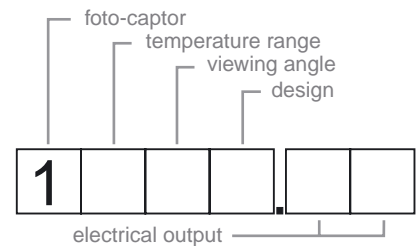

The captor group



For over 40 years weber Sensors has been a leader in sensor innovation worldwide. From these activities the captor group evolved, providing engineered solutions for industrial automation and factory floor communication throughout the world.

The captor group is a unification of companies from a variety of industries and technologies addressing the marketplace under the captor umbrella. The members of the captor group are sharing resources and Know How and - most important - share and benefit from the market recognition of the trade mark "captor",

that stands for products and services you can rely on. Members of the captor group are world-wide. For more information, please write to info@captor.com.

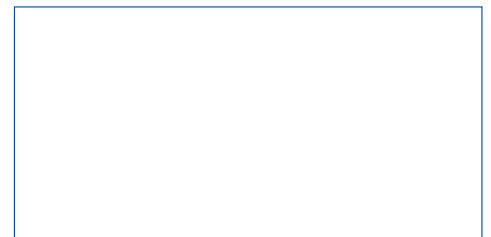

weber
Sensors Inc

Member of the captor Group

2230 Towne Lake Pkwy., Bldg. 900, Suite 200 • Woodstock, GA 30189

Phone: +1(770) 592-6630 • Fax: -6640 • E-mail: info@captor.com • www.captor.com